



NORWEST

MANUFACTURING

71 SOUTH 215 WEST-RUPERT, ID- PHONE: (208) 436-1770 - FAX: (208) 436-1776

SECTION 200 -20 S-TINES, SHANKS & FOOT PIECES



DANISH

DANISH "S" TINE SHANKS

PART NUMBER	DESCRIPTION	MATERIAL	WEIGHT	A	B	C	D	E	F
				SEE FIGURE 1					
S6620	SHORT; FOR RAU W/POINT (6.4mm)	1/4" X 1"	2.41 LBS.	7"	12-1/2"	8-1/2"	3-7/8"	3-1/8"	2-3/4"
S6623	STANDARD SHANK (10mm)	3/8" X 1-1/4"	5.87 LBS.	12-5/8"	21"	14-1/4"	6-5/8"	5"	4-1/2"
S6624	HEAVY DUTY SHANK (12mm)	1/2" X 1-1/4"	7.03 LBS.	12-5/8"	21"	14-1/2"	6-11/16"	5-1/2"	4-3/4"
S6668	HIGH CLEARANCE SHANK (12mm)	1/2" X 1-1/4"	7.35 LBS.	12"	25-7/8"	19-1/4"	6-1/2"	5"	4"
S6670	HEAVY DUTY; HIGH CLEARANCE SHANK (12mm)	1/2" X 1-3/4"	11.27 LBS.	13-5/8"	26"	19-1/2"	6-9/16"	5-3/8"	5-1/8"
S6672	PENETRATOR TINE (12mm)	1/2" X 1-1/2"	8.95 LBS.	11"	22-1/4"	15-5/8"	6-5/8"	5-1/2"	5"
S6680		1/2" X 1-3/4"		12"	26"	19-1/2"	6-1/2"	8-1/2"	3-1/2"
S6690		1/2" X 2"			26"	19"	6"	6-3/4"	3-1/2"
				SEE FIGURE 2					
S6674	TRUE DEPTH; VERTICAL MOUNT SHANK for ALLOWAY & ELMERS (15.9mm) (Clamps not Available)	5/8" x 1-3/4"	13.95 LBS.	13-3/8"	30"	20-5/8"	--	--	--
S6675		1/2" X 1-3/4"		12-1/2"	30-1/2"	23"	--	--	--

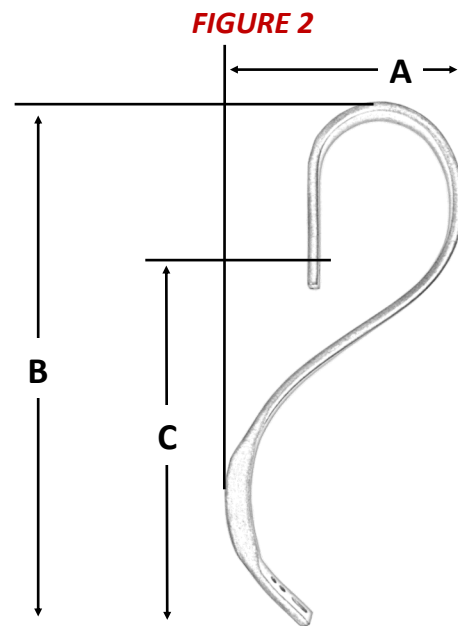
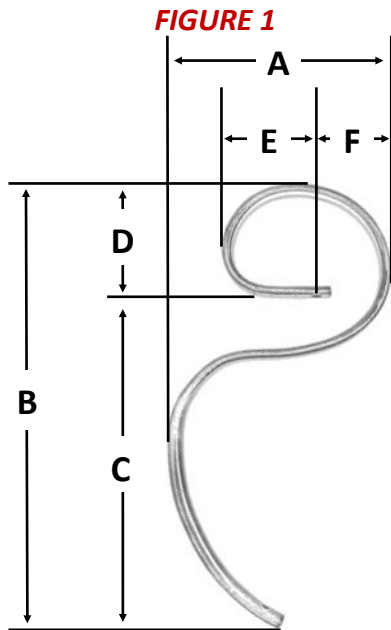

DANISH "S" TINE FOOT PIECE MEASUREMENTS

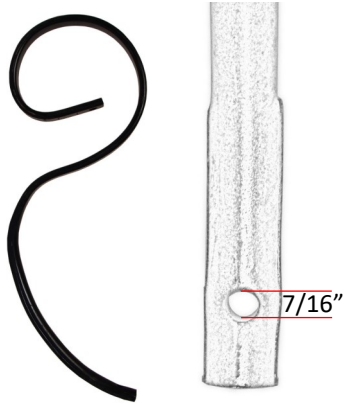

S6623, S6624 & S6668

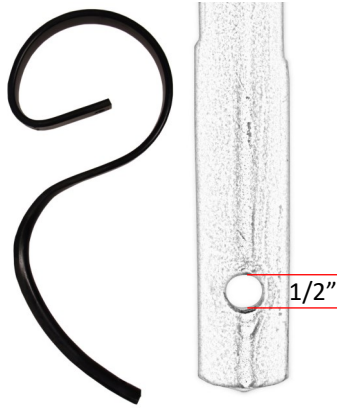

S6670

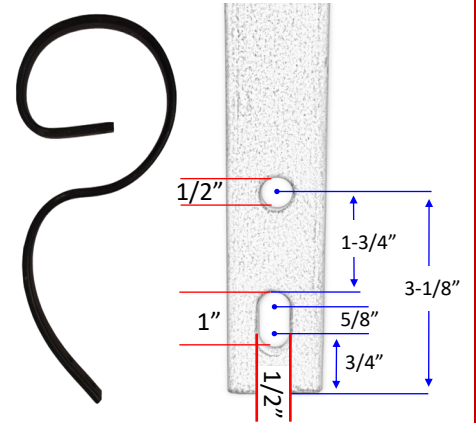

S6672

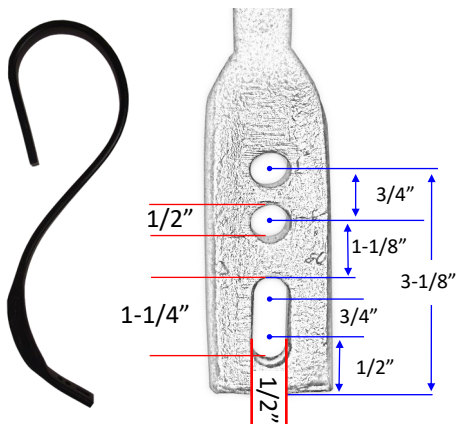

S6674

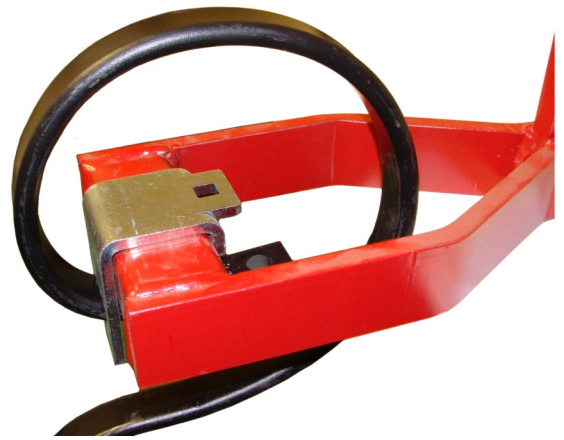

DANISH "S" TINE CLAMPS

PART	PART NUMBER	USED ON	BAR SIZE	WEIGHT
<p>↑ SC2130 x SC2165 ↓</p>	SC2120	Danish "S" Tine Clamp for 6.4mm Tines (1/4")	1.5" Bar	0.30 LBS.
	SC2130	Danish "S" Tine Clamp for 10mm or 12mm Tines (3/8" or 1/2")	3/8" x 2" Bar	0.55 LBS.
	SC2150	Danish "S" Tine Clamp for 10mm or 12mm Tine (3/8" or 1/2")	2" Square Bar	0.70 LBS.
	SC2155	Danish "S" Tine Clamp for 32mm X 10 mm or 12mm Tine (1-1/4" x 3/8" or 1/2")	2-1/2" Square Bar	1.00 LBS.
	SC2160	Danish "S" Tine Clamp for 45mm X 12mm Tine (1-3/4" x 1/2")	2" Square Bar	1.00 LBS.
	SC2165	Danish "S" Tine Clamp for 45mm X 12mm Tine (1-3/4" x 1/2")	2-1/2" Square Bar	1.19 LBS.
	SC2166	Danish "S" Tine Clamp for 45mm X 12mm Tine (1-3/4" x 1/2")	3" Square Bar	1.39 LBS.

DANISH "S" TINE SWEEPS & POINTS

PART #	SIZE	ORIGIN	MEAS. (A)	MEAS. (B)
TPVA01	1/4" X 1"	IMPORT	8" <i>POINT</i>	1-5/8"
TPVA01T*	1/4" X 1"	IMPORT	8" <i>POINT</i>	1"
<i>*This point is used to Scratch & Thatch Hay</i>				
TPVA15	1/4" X 1-1/2"	IMPORT	8-1/2" <i>POINT</i>	1-3/4"
TPVA25	1/4" X 2"	IMPORT	10" <i>POINT</i>	2"
TPVA02	1/4" X 2-3/4"	IMPORT	N/A	2-3/4" GOOSE FOOT
TPVA04	1/4" X 4"	IMPORT	N/A	4" GOOSE FOOT
TPVA44	1/4" X 4"	IMPORT	N/A	4" WINGED
TPVA07	1/4" X 7"	IMPORT	N/A	7" WINGED
TPVA09	1/4" X 9"	IMPORT	N/A	9" WINGED
TPVA10	1/4" X 10"	IMPORT	N/A	10" WINGED
TPVM07	1/4" X 7"	DOMESTIC	N/A	7" WINGED
TPVM10	1/4" X 10"	DOMESTIC	N/A	10" WINGED

SOLID CHROME SWEEPS & POINT

CVS-01	<i>SOLID CHROME</i>	IMPORT	6" <i>POINT (non-reversible)</i>	1"
CVS-02	<i>SOLID CHROME</i>	IMPORT	N/A	2-3/4" GOOSE FOOT
CVS-04	<i>SOLID CHROME</i>	IMPORT	N/A	4" GOOSE FOOT
CVS-07	<i>SOLID CHROME</i>	IMPORT	N/A	7" WINGED

MORE SWEEPS AVAILABLE. REFER TO: SECTION 100 - TILLAGE

♦ Chrome Danish Sweeps & Point Inset Below ♦

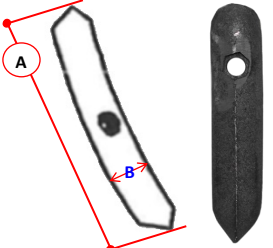
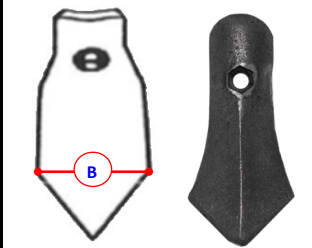
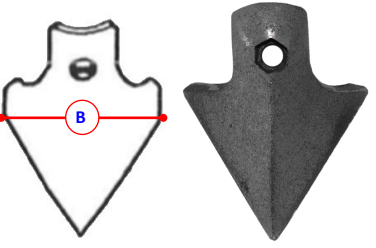
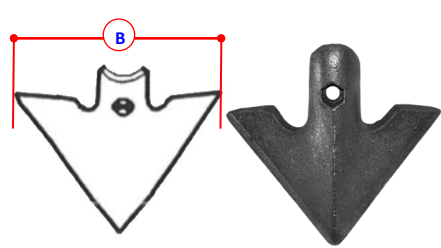
			
REVERSIBLE DANISH POINT	GOOSE FOOT SWEEP	4" GOOSE FOOT SWEEP	WINGED DANISH SWEEP

ELLIPTICAL HEAD BOLTS for NON-CHROME DANISH APPLICATIONS

HEX BOLTS for CHROME DANISH APPLICATIONS

	PART #	DESCRIPTION	PART #	DESCRIPTION
	SB3858	Danish 3/8" x 1-1/2" Elliptical Head Bolt w/Nut	FHB38150G5	3/8" x 1-1/2" Hex Bolt less Nut
	SB3878	Danish 3/8" x 1-3/4" Elliptical Head Bolt w/Nut	FHN38	3/8" Hex Nut <i>(Sold Separately)</i>

**Sweeps may be ordered HARDFACED*

***Not all styles in stock.*

Call Norwest Mfg. for pricing and availability.

www.norwest-mfg.com



NORWEST
MANUFACTURING



**1" Spike
CVS-01H**



**2" Goosefoot
CVS-02H**



**4" Sweep
CVS-04H**



**7" Sweep
CVS-07H**

Heavy Duty Chrome Carbide S-Tine Sweeps & Point

- ◆ Fits on a Wider Variety of S-Tines & Tine Machines
- ◆ Will Outwear Stamped Metal Sweep 3 to 4 Times!
- ◆ Has a new and Improved Cutting Edge
 - Wears Sharper & Longer
- ◆ Available: *JANUARY 2016*

CALL & PLACE YOUR ORDER TODAY!!

All Heavy Duty Chrome Carbide Danish S-Tine Sweeps come with rubber shim & mounting hardware.



71 South 215 West, Rupert Idaho - 83350 • Phone: (208) 436-1770 • Fax: (208) 436-1776 • www.norwest-mfg.com

Chrome Carbide Danish S-Tine Sweeps & Point

PART #	SIZE	ORIGIN	MEAS. (A) See Page 200-204 to Determine Measurements	MEAS. (B) See Page 200-204 to Determine Measurements
CVS-01H	SOLID CHROME	IMPORT	6" Spike	1"
CVS-02H	SOLID CHROME	IMPORT	N/A	2-3/4" GOOSE FOOT
CVS-04H	SOLID CHROME	IMPORT	N/A	4" SWEEP
CVS-07H	SOLID CHROME	IMPORT	N/A	7" SWEEP

All HD Chrome Carbide S-Tine Sweeps include Rubber Shim & Mounting Hardware

				
1" Spike	2" Goosefoot	4" Sweep	7" Sweep	Rubber Shim & Mounting Hardware

COIL SHANKS

1" & 1-1/4" COIL SHANKS

PART NUMBER	DESCRIPTION	MATERIAL	WEIGHT	A	B	C	D
S506	VERTICAL MOUNT	1" X 1"	22.21 LBS.	38-1/2"	19"	8"	3-1/8"
S507	VERTICAL MOUNT	1-1/4" x 1-1/4"	36.35 LBS.	38"	18-1/2"	9"	4"

HOLE SPACING: 1-3/4" - 2-1/4" to Accommodate Various Field Cultivator Points.
USE WITH: 4040A Clamp for 2-1/4" \diamond Bars or 4040LP Clamp for 4" X 4" Tool Bars

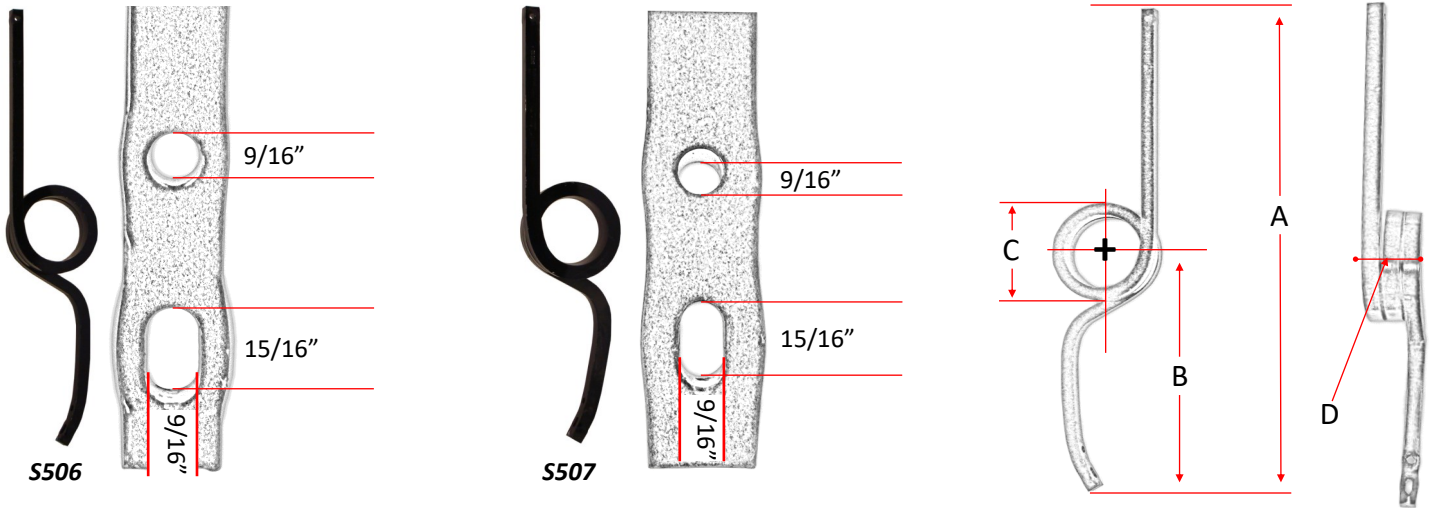

SINGLE ROW "S" TINE CULTIVATORS





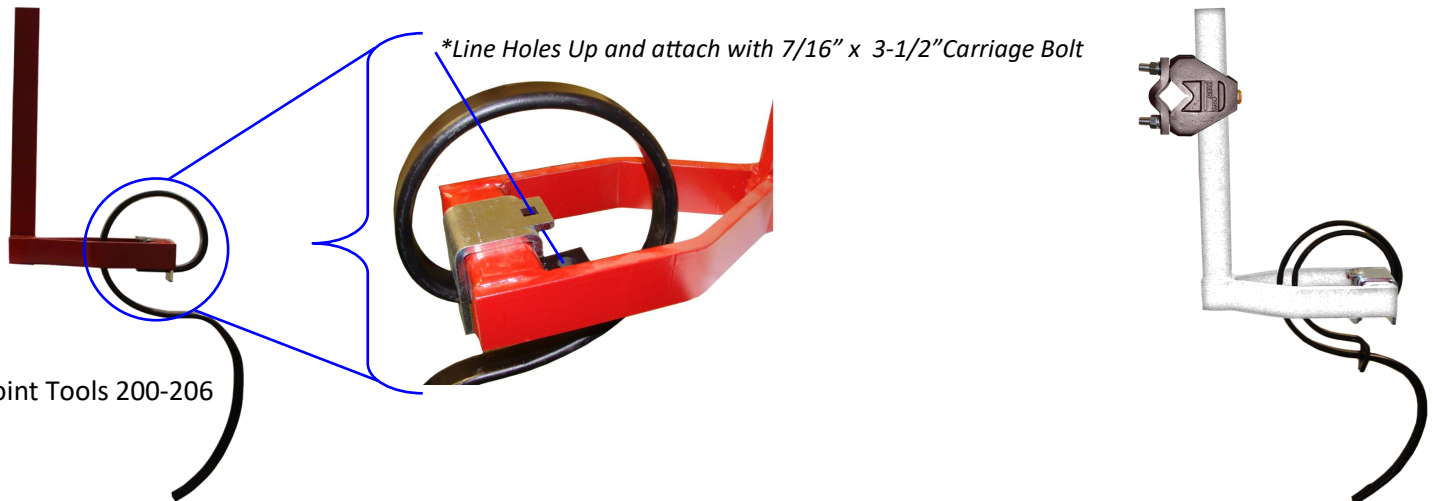







PICTURE	PART NUMBER	DESCRIPTION	MATERIAL
	S-101A	Single Shank Bracket Less "S" Tine	5/8" X 2" Shank
	S-101HA	Heavy Duty Single Shank Bracket Less "S" Tine	1" X 3" Shank

Bottom Left Photo: S-101A with S6624 S-Tine & SC2150 S-Tine Clamp
Bottom Right Photo: S-101A with S6623 S-tine, S6623H Helper Spring, SC2160 S-Tine Clamp & 342R Cast Clamp





Center Buster Shanks

NORWEST PART #	DESCRIPTION	CHROME TIP	CHROME EDGE	WEIGHT
SC-30	5/8" X 2" X 30" Plain Shank; LESS Chrome Point	--	--	10.54 LBS.
SC-N30	5/8" X 2" X 30" Shank; With CJD20 bolt-on High Chrome Alloy Point		--	11.05 LBS.
SC-34	3/4" X 2-1/2" X 34" Plain Shank; Less Chrome Point	--	--	17.28 LBS.
SC-N34	3/4" X 2-1/2" X 34" Shank; With CJD20 bolt-on High Chrome Alloy Point		--	17.98 LBS.
Z-SCCN30	5/8" X 2" X 30" Standard; with CN3034 Chrome Edging	--		12.32 LBS.
SCC-N30	5/8" X 2" X 30" Standard; with CJD20 Chrome Point and CN3034 Chrome Edging			13.34 LBS.
Z-SCCN34	3/4" X 2-1/2" X 34" Standard; with CN3034 Chrome Edging	--		18.11 LBS.
SCC-N34	3/4" X 2-1/2" X 34" Standard; with CJD20 Chrome Point and CN3034 Chrome Edging			19.13 LBS.
SC-34ST	3/4" X 2-1/2" X 34" Straight Shank; LESS Chrome	--	--	15.28 LBS.
SC-N34ST	3/4" X 2-1/2" X 34" Straight Shank; with CJD21 Chrome Point		--	16.30 LBS.
S-130	1" X 3" X 36" Sundance Shank; Less Chrome	--	--	33.52 LBS.
SC-SD130	1" X 3" X 36" Sundance Shank; with C1030 Chrome Shin Guard	--		36.91 LBS.
SCP-SD130	1" X 3" X 36" Sundance Shank; with C1030 Chrome Shin Guard and CD-830 High Alloy Chrome Point			39.09 LBS.
SCP-SD3425	3/4" X 2-1/2" X 36" Sundance Shank; beveled, hard faced, with CD-830 High Alloy Chrome Point		--	36.01 LBS.

For More Information on Chrome Alloy Applications, Please Refer to:
Section 700 - Chrome Alloy

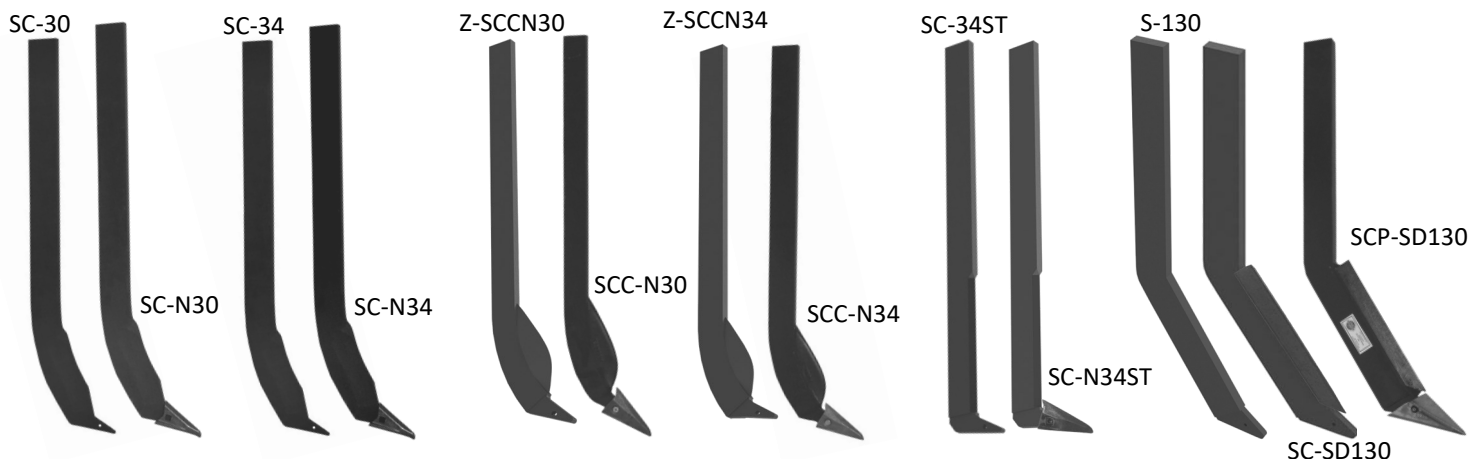

TILLAGE TOOLS for GRAINGER APPLICATIONS



Norwest Part #
G-6L



Norwest Part #
SGP-EDP20



Norwest Part #
TPGS-EDP

PART #	DESCRIPTION	DIMENSIONS	WEIGHT EACH (Approx.)
SHOVEL CORRUGATORS for GRAINGER			
G-6S	Grainger Style 6" Small Shovel Corrugator	6" Height x 24" Long	23.22 LBS.
G-6L	Grainger Style 8" Large Shovel Corrugator	8" Height x 24" Long	30.95 LBS.
SHANKS for GRAINGER			
SGP-EDP20	5/8" X 2" Shank with TPGS-EDP Point	5/8" X 2" X 31-1/2"	11.07 LBS.
CHROME POINTS for GRAINGER SHANKS			
TPGS-EDP	Solid Steel Point for Grainger Shank	3/8" X 1-5/8" x 3-1/2"	0.46 LBS.
For additional tillage parts refer to: SECTION 100 - TILLAGE			



Norwest Part #'s
SGP-EDP20 Shank
shown with
G-6L Shovel Corrugator

www.norwest-mfg.com

***Not all styles in stock. Call Norwest Mfg. for pricing and availability.*

NORWEST

Shanks & Standards

Norwest Shanks and Standards are made of Carbon Spring Steel and are of unsurpassed quality. A complete range of sizes are available in both the Forged Foot and Straight Shank designs. Upper holes are not available in any **Forged Foot** shank.

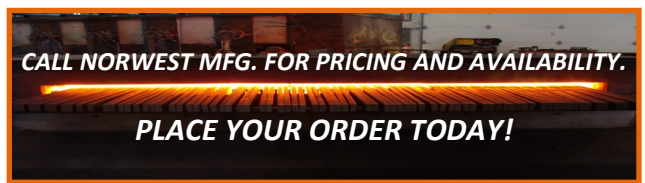
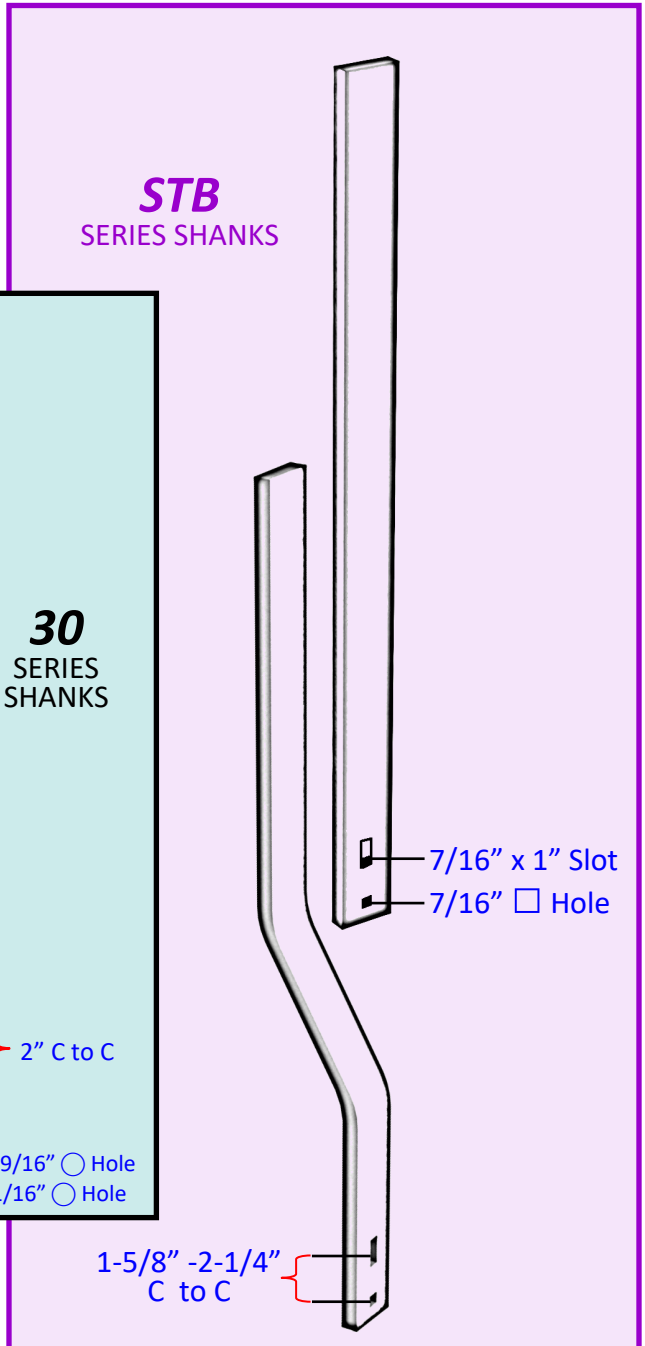
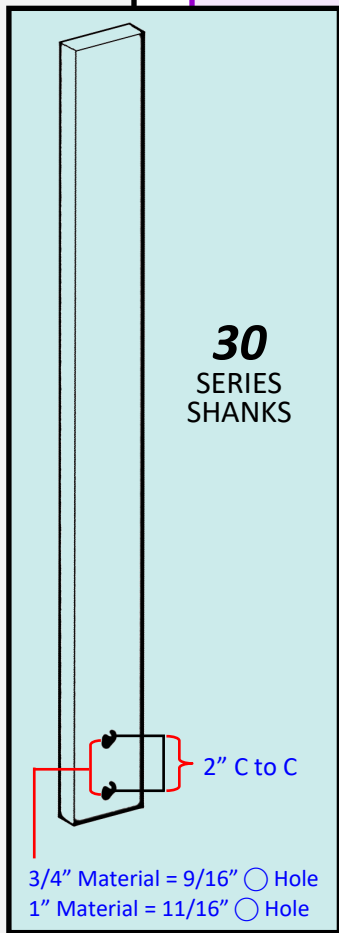
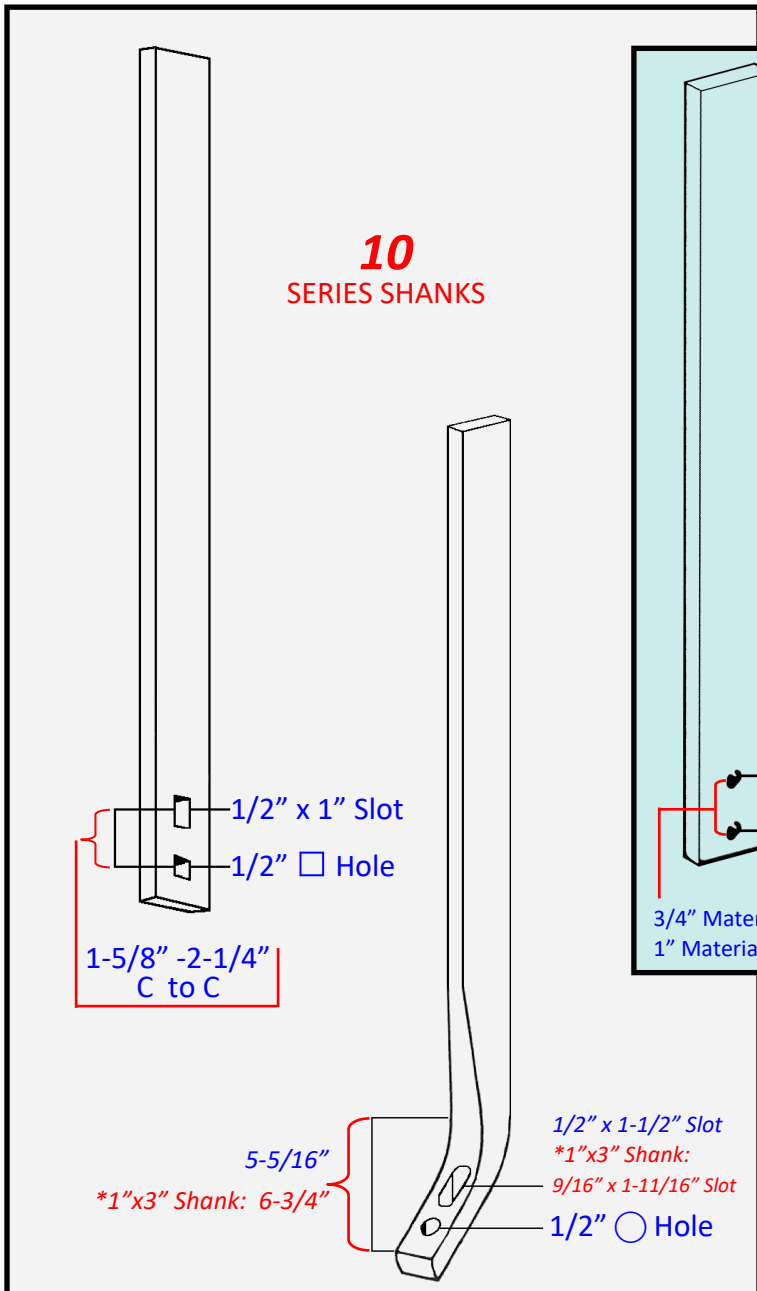



www.norwest-mfg.com

STRAIGHT / FLAT

Cultivator Shanks & Standards

STRAIGHT / FLAT SHANKS

PART	PART NUMBER	HOLE/SLOT SIZE	DESCRIPTION	WEIGHT
	10 SERIES SHANKS: Rigid Straight Cultivator Shanks			
	108011	1/2" □ Hole 1/2" x 1" Slot	5/8" X 1-1/2" X 24"	6.38 LBS.
	108083	1/2" □ Hole 1/2" x 1" Slot	5/8" X 1-1/2" X 26"	6.92 LBS.
	108012	1/2" □ Hole 1/2" x 1" Slot	5/8" X 2" X 28"	9.95 LBS.
	108014	1/2" □ Hole 1/2" x 1" Slot	3/4" X 2-1/2" X 28"	14.92 LBS.
	30 SERIES STANDARDS: Rigid Straight Cultivator Shanks			
	S3426	9/16" ○ Hole	3/4" X 2-1/2" X 26" (Std. 2 Hole: See Below)	13.83 LBS.
	S3022	11/16" ○ Hole	1" X 3" X 22" (Multi-Hole: See Below)	18.77 LBS.
	S3030	11/16" ○ Hole	1" X 3" X 30" (Standard 2 Hole)	26.65 LBS.
	S3032	11/16" ○ Hole	1" X 3" X 32" (Standard 2 Hole)	27.23 LBS.
	S3036	11/16" ○ Hole	1" X 3" X 32" (Standard 2 Hole)	30.60 LBS.
	S3042	11/16" ○ Hole	1" X 3" X 42" (Standard 2 Hole)	35.70 LBS.
	S3048	11/16" ○ Hole	1" X 3" X 48" (Standard 2 Hole)	40.80 LBS.
	STB SERIES STANDARD: Rigid Straight Cultivator Shank			
	STB-10	7/16" □ Hole 7/16" x 1" Slot	5/8" X 2" X 30"	10.38 LBS.

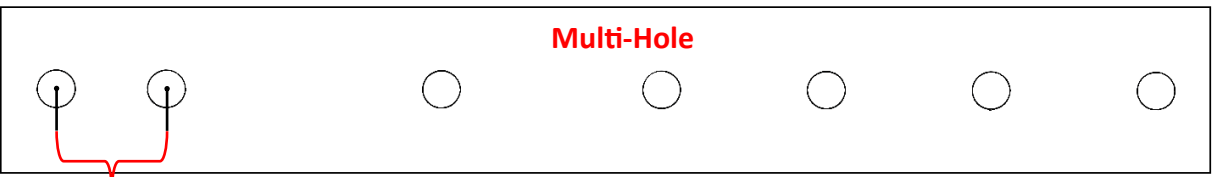
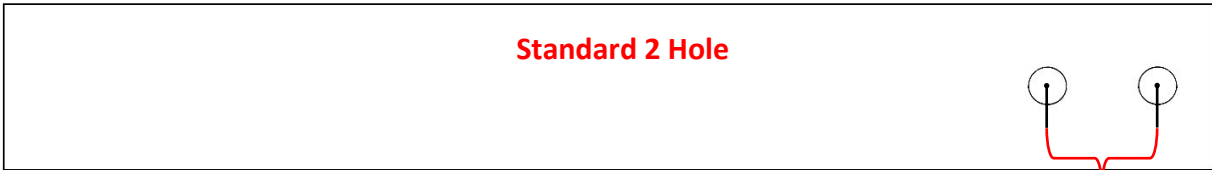

FORGED FOOT

Cultivator Shanks & Standards



FORGED FOOT SHANKS

PART	PART NUMBER	HOLE/SLOT SIZE	DESCRIPTION	WEIGHT
	108001	1/2" x 1-1/2" Slot; 1/2" ○ Hole	5/8" X 2" X 30"	10.08 LBS.
	108084	1/2" x 1-1/2" Slot; 1/2" ○ Hole	5/8" X 1-1/2" X 26"	6.55 LBS.
	108002	1/2" x 1-1/2" Slot; 1/2" ○ Hole	3/4" X 2-1/2" X 30"	15.69 LBS.
	108071	1/2" x 1-1/2" Slot; 1/2" ○ Hole	3/4" X 2-1/2" X 36"	19.13 LBS.
	108056	9/16" x 1-11/16" Slot; 1/2" ○ Hole	1" X 3" X 36"	30.60 LBS.

FLAT & FORGED FOOT OFFSET

Cultivator Shanks & Standards

FLAT & FORGED FOOT OFFSET SHANKS

PART	PART NUMBER	HOLE/SLOT SIZE	DESCRIPTION	WEIGHT
	STB SERIES: Side Offset Cultivator Standard			
	STB-20	7/16" □ Hole; 7/16" x 1" Slot	5/8" X 2" X 30"	10.37 LBS.
	30 SERIES: Side Offset Cultivator Standard			
STB-20	S30320S	11/16" ○ Holes	1" X 3" X 32" (to Fit FP Style)	26.65 LBS.
	10 SERIES: Side Offset Cultivator Standard			
	108001L (Left)	1/2" x 1-1/2" Slot; 1/2" ○ Hole	5/8" X 2" X 30"	10.08 LBS.
	108001R (Right)			
	108071L (Left)	1/2" x 1-1/2" Slot; 1/2" ○ Hole	3/4" X 2-1/2" X 36"	19.13 LBS.
	108071R (Right)			
	108056L (Left)	9/16" x 1-11/16" Slot; 1/2" ○ Hole	1" x 3" x 36"	30.60 LBS.
108056R (Right)				

www.norwest-mfg.com



SPECIALIZED

Cultivator Shanks & Standards

RIGID STANDARDS with FOOT PIECE

PART	PART NUMBER	MATERIAL	DESCRIPTION	WEIGHT
 SF3000	SF3400	3/4" X 2-1/2" X 30" with 9/16" O Holes	S3426 with Adjustable FP34 Foot Piece Uses: (1) 1/2" x 2-1/2" Hex Bolt & (1) 1/2" x 2" Hex bolt	22.41 LBS.
	SF3000	1" X 3" X 30" with 11/16" O Holes	S3030 with Adjustable FP10 Foot Piece Uses: (1) 5/8" x 3" Hex Bolt & (1) 5/8" x 2-1/2" Hex bolt	31.97 LBS.
	SF3600	1" X 3" X 36" with 11/16" O Holes	S3036 with Adjustable FP10 Foot Piece Uses: (1) 5/8" x 3" Hex Bolt & (1) 5/8" x 2-1/2" Hex bolt	37.07 LBS.

ROUND STANDARDS

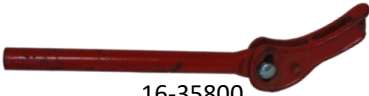

PART	PART NUMBER	DESCRIPTION	WEIGHT
 Z-2183-3153427	Z-2183-3153427	1-3/8" X 24-1/4" O Shank with 3/4" Hole	9.90 LBS.
 16-35801	16-35801	1-1/4" X 19" O Shank with 9/16" Holes	6.40 LBS.

ROUND STANDARD with FOOT PIECE

PART	PART NUMBER	DESCRIPTION	WEIGHT
 16-35800	16-35800**	1-1/4" X 19" O Shank with Adjustable 16-35802 Cast Foot Piece Uses: (1) 1/2" X 2" Hex Bolt & (1) 1/2" X 2-1/2" Carriage Bolt	11.50 LBS.

**** For More Information on this complete unit and its uses, REFER to SECTION 1100: SPIDER CULTIVATORS**

NORWEST SPRING TRIP SHANK

PART	PART NUMBER	DESCRIPTION	WEIGHT
 108071-STF	108071-STF	Norwest Spring Trip Shank 3/4" x 2-1/2" x 36" with Forged Foot	25.00 LBS.
 108071-STD	108071-STD	Norwest Spring Trip Shank 3/4" x 2-1/2" x 36" with TPVA25 Heavy Reversible Danish Point 10" x 2" x 1/4" (Import)	26.40 LBS.

www.norwest-mfg.com



NORWEST

MANUFACTURING

71 SOUTH 215 WEST-RUPERT, ID- PHONE: (208) 436-1770 - FAX: (208) 436-1776

FOOT PIECES

PART	PART NUMBER	HOLE CENTERS	DESCRIPTION	WEIGHT
	FP10 <i>(Fabricated)</i>	2" Hole Centers	Adjustable Foot Piece for 1" x 3" Standards w/ Set Screw	6.35 LBS.
	FP10H <i>(Fabricated)</i>	2" Hole Centers	Adjustable Foot Piece for 1" x 3" Standards w/ Set Screw	6.46 LBS.
	FP10S <i>(Fabricated)</i>	2" Hole Centers	Adjustable Foot Piece (MULTI-HOLE SLIP STYLE) for 1" x 3" Standards w/ Fasteners	6.46 LBS.
	FP10SMA1 <i>(Fabricated)</i>	5" Hole Centers	Adjustable Foot Piece (MULTI-HOLE SLIP STYLE) for 1" x 3" Standards	6.46 LBS.
	FP10SMA2 <i>(Fabricated)</i>	5" Hole Centers	Adjustable Foot Piece (SIMPLE SLIP STYLE) for 1" x 3" Standards	6.46 LBS.
	FP34 <i>(Fabricated)</i>	2" Hole Centers	Adjustable Foot Piece for 1" x 3" Standards w/ Set Screw	6.65 LBS.
	16-35802 <i>(Cast)</i>	2" Hole Centers	Adjustable Foot Piece for 3/4" Standards w/(2) 16-35805 ratchet washer w/ear <i>(inset: Ratchet Washers Sold Separately. Shown for Assembly Purposes Only)</i>	4.74 LBS.

www.norwest-mfg.com